

## Synthra MeI (MeOTf) (Catalog No. 005)

Synthra MeI is a flexible and completely automated radiosynthesizer for the efficient production of [ $^{11}\text{C}$ ]methyl iodide and [ $^{11}\text{C}$ ]methyl triflate. Automating the synthesis is simple with the easy-to-use configuration software SynthraView. The Synthra MeI module offers both fully automatic and manual modes of operation.

### Gas Phase Capabilities

- ✓ High specific activities are achieved from in-target produced [ $^{11}\text{C}$ ]CO<sub>2</sub> ranging from 5 Ci/ $\mu\text{mol}$  to 20 Ci/ $\mu\text{mol}$  (Higher specific activities are possible when using methane target).

The [ $^{11}\text{C}$ ]CO<sub>2</sub> produced in target is quantitatively trapped in the stainless steel capillary tubing at -180 °C. Subsequently, the CO<sub>2</sub> is released into the methane oven where it is converted to [ $^{11}\text{C}$ ]CH<sub>4</sub> by reduction on a Ni-catalyst. The [ $^{11}\text{C}$ ]CH<sub>4</sub> is trapped at -120 °C on Carboxen®. In a successive gas phase reaction the iodination of [ $^{11}\text{C}$ ]CH<sub>4</sub> to [ $^{11}\text{C}$ ]MeI is carried out in a gas phase recirculation system with gaseous I<sub>2</sub> at 730 °C. During circulation [ $^{11}\text{C}$ ]MeI accumulates on a Porapak™ column. Finally, it is released at 200°C and ready for any kind of labeling reaction.

### [ $^{11}\text{C}$ ] Labeling Possibilities

- ✓ **[ $^{11}\text{C}$ ]Methyl iodide production:** [ $^{11}\text{C}$ ]MeI is ready for release 7 minutes after trapping the [ $^{11}\text{C}$ ]CO<sub>2</sub>. The yield for the [ $^{11}\text{C}$ ]methyl iodide formation is under good conditions above 50 % non-decay corrected. (ndc).
  - Up to 10 sequential methyl iodide preparations are possible from a single box set-up.
- ✓ **Methyl triflate production:** The [ $^{11}\text{C}$ ]MeI can be converted to [ $^{11}\text{C}$ ]MeOTf by passing through a silver triflate filled column at 180 °C. The possible conversion yield from methyl iodide is 95 %.

### Additional Gas Phase Options

- ➔ **Methane option:** A reduced gas phase suitable for the use of CH<sub>4</sub> target
- ➔ **[ $^{11}\text{C}$ ]HCN** (Catalog No. 003hcn): The [ $^{11}\text{C}$ ]CH<sub>4</sub> is released with NH<sub>3</sub> gas into a high temperature area where it undergoes a Pt-catalyzed conversion into [ $^{11}\text{C}$ ]HCN at 950 °C.



### General Features

- ✓ **Heating and cooling capabilities**
  - Seven heating zones
  - Four with cooling capabilities
  - Temperature range: -196 °C – 950 °C
- ✓ **Detectors and controllers**
  - Three shielded radiation detectors
  - Three electronic flow controllers (HCN option: Four flow controllers)
  - One pressure sensor as leak detector
- ✓ **Chemically inert valves** with small dead volume < 35  $\mu\text{L}$ , 5 bar rated
- ✓ **Size** (w x d x h): 30 x 50 x 48 cm
- ✓ **Weight:** approx. 20 kg

### Synthesis Features

- ✓ **Triflate/column oven** (RT – 200 °C)

# Synthra C-11 Family

## Product Description and Technical Specifications

synthra



### GMP Features

- ✓ Synthesis files for  $[^{11}\text{C}]\text{MeI}$  and  $[^{11}\text{C}]\text{MeOTf}$
- ✓ **GMP compliant.** Electronic control and data collection (27/18 channels)
- ✓ **21CFRpart11** & **LIMS** compatible

### Terminal Control

- ✓ A laptop (Win 10 Pro) with preinstalled controlling software SynthraView is included
- ✓ Four digital inputs for communication with external devices

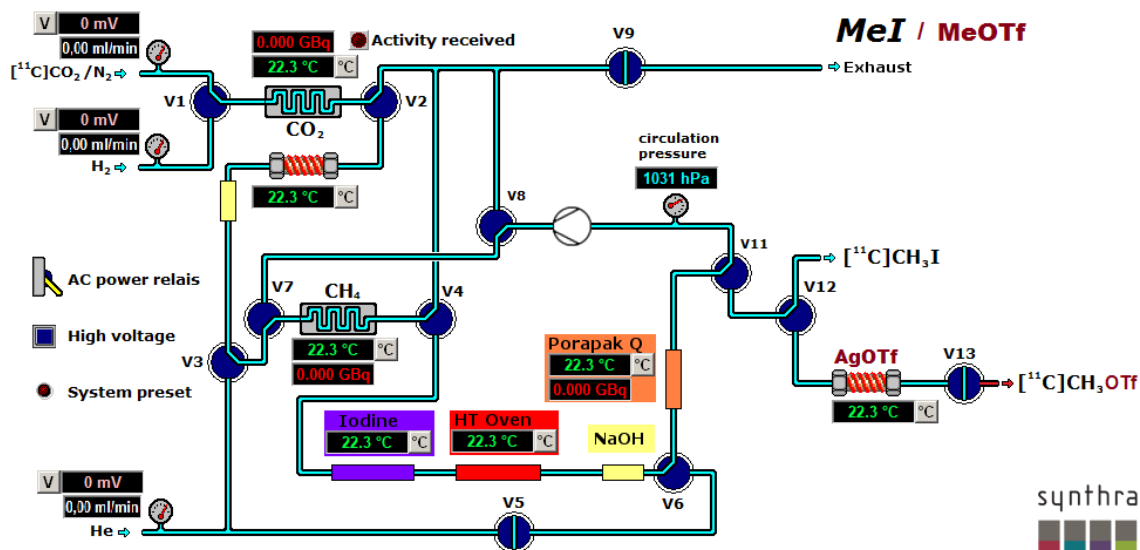

The Graphical User Interface (GUI) of the SynthraView software.